

LAMINAR FLOW HEPA DIFFUSER

2-WAY FULL-FACE

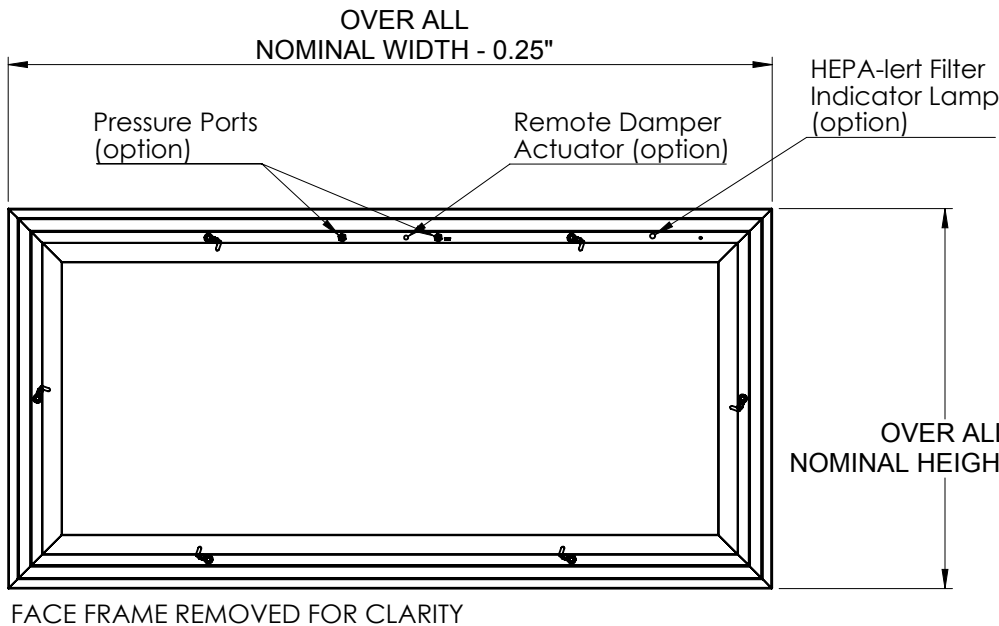
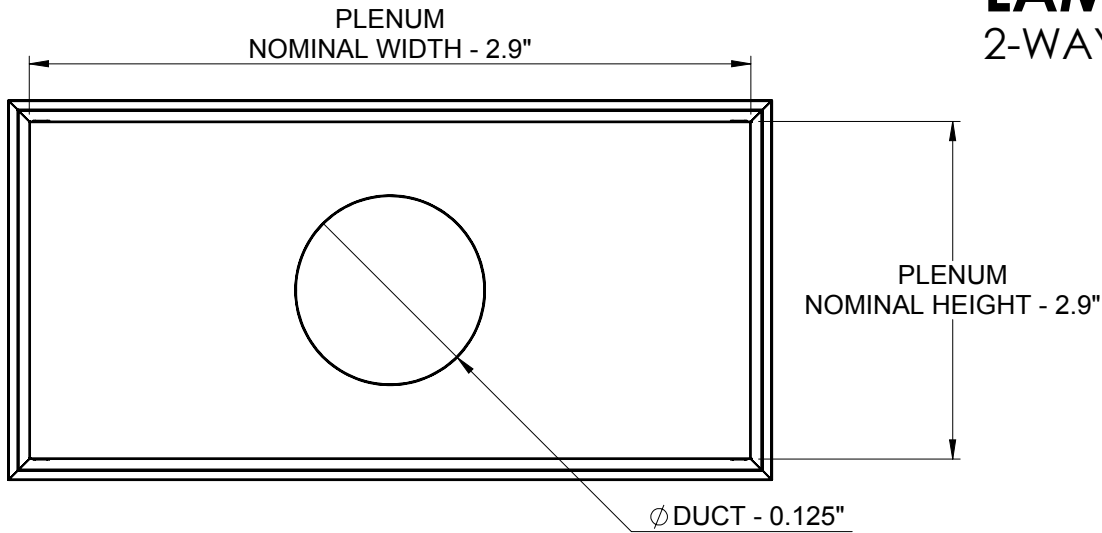

OPTIONS

- 316 Stainless Steel
- Aluminum
- White Epoxy Powdercoat Finish
 - other color _____
- Side Inlet
- End Inlet
- Rectangle Inlet _____
- Oval Inlet _____
- Butterfly Damper
- Radial Damper
- Remote Damper
- HEPA-ert Filter Monitor
 - Battery
 - 24V Supply
- (1) Pressure Port
- (2) Pressure Port
- PAO Challenge Manifold
- ULPA Filter
- MERV 14 Filter

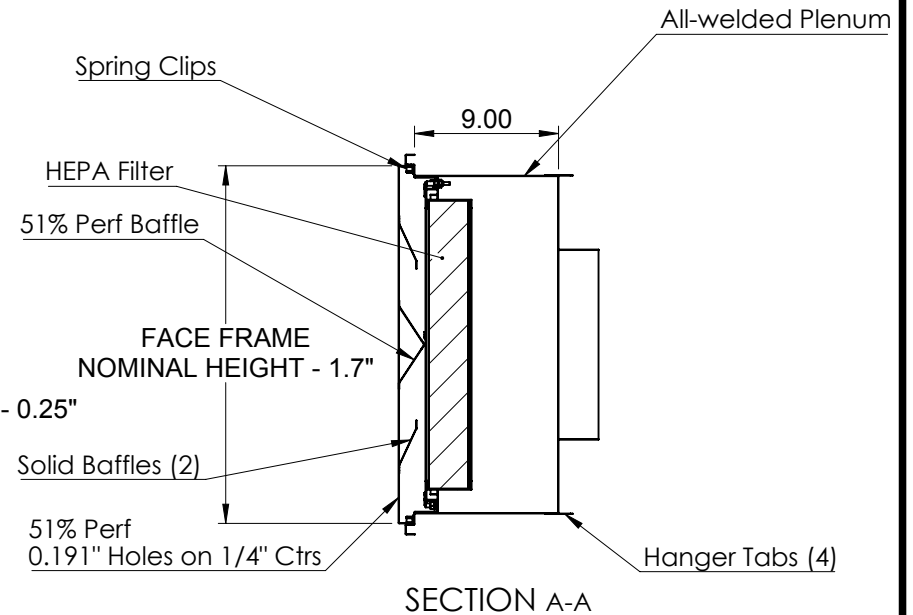

AJMFG
 PO BOX 270320
 3601 EAST 18 STREET
 KANSAS CITY MO 64127-0320
 PH:816-231-5522 FAX:816-231-8437
 800-247-5746 EMAIL:SALES@AJMFG.COM
 VISIT OUR WEB SITE AT:WWW.AJMFG.COM

FRD-HEPA

DIMENSIONS ARE IN INCHES/LBS UNLESS OTHERWISE SPECIFIED.
 DIMENSIONS IN PARENTHESIS ARE FOR REFERENCE ONLY.
 TOLERANCES: ANGULAR, MACH ± 1°, BEND ± 1°, TWO DECIMALS ± .03;
 THREE DECIMAL ± .010; THREE DECIMALS FOR LASER ± .005.
 REMOVE ALL SHARP EDGES AND BURRS.

THIS DRAWING INFORMATION IS THE SOLE PROPERTY OF A-J MFG. CO., INC.
 ANY REPRODUCTION IN PART OR WHOLE WITHOUT THE WRITTEN PERMISSION
 OF A-J MFG. CO., INC. IS PROHIBITED. PROPRIETARY AND CONFIDENTIAL

DRAWN
HT

CHKD

APRVD

MATERIAL
304SS

FINISH
#4 SATIN

SIZE

JOB NAME

ENGINEER

CONTRACTOR

TAG

QTY

REV #

SHT 1/1

SCL 1:12

DO NOT SCALE