

Job Name: _____

Tag Name: _____ Quantity: _____

Unit Size: W _____ x H _____

STAINLESS STEEL

250 Lay-In Frame

LAY-IN FRAME FOR HARD CEILING

Minimum Unit: W 4" x H 4"
Maximum Unit: W 48" x H 48"

OPTIONS

- 304 Stainless Steel **(Standard)**
 - #4 Satin Polish **(Standard)**
- 316 Stainless Steel
 - #4 Satin Polish
- White Antimicrobial Epoxy Powdercoat Finish
- Other Color _____
- Countersunk Mounting Screw Options:
 - Neck Holes **(Standard)**
 - Surface Mount w/Neck Holes
 - No Holes

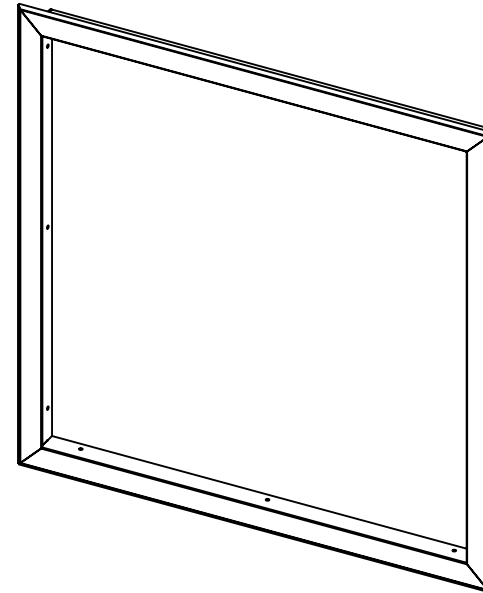

Select Lay-In Grille Model Below for Proper Frame Order Size (Must Select One)

<input type="checkbox"/> Order Size +3.187"	<input type="checkbox"/> Order Size +2.187"	<input type="checkbox"/> Order Size +0.187"	<input type="checkbox"/> Order Size +0.437"
Any Style SSHFG or SSFG	150, 250, 550, SSG, SSEC, SSBG, SSLBG, SSPERF, SSMCD, SSMLCD, SSCB, SSDL, SSCLCD, SSDG	SSPLT, FRD, FRD-HEPA, HRDP, HRDP-HEPA, SSLF, SSLFHD, SSLFHD-FP, SSLFHD-FFU, SSHEMI, SSHEM-HEPA	SSEPD

* To maintain AJ Manufacturing's policy of continuous product improvement, we reserve the right to change any information concerning product or pricing without notice or obligation *



8701 Elmwood Ave #400
Kansas City, MO 63132
Ph: 816-231-5522 Fax: 816-231-8437
800-247-5746 Email: robhaake@ajmfg.us
Please Visit Our Web Site At: www.ajmfg.com

DRAWN SLG	MATERIAL 304SS	JOB NAME	TAG	QTY	REV # A
CHKD	FINISH #4 SATIN	ENGINEER	DRAWING NAME 250 Lay-In		SHT 1/2
APRVD	SIZE	CONTRACTOR			SCL 1:10
					DO NOT SCALE

250 Lay-In Frame

LAY-IN FRAME FOR HARD CEILINGS

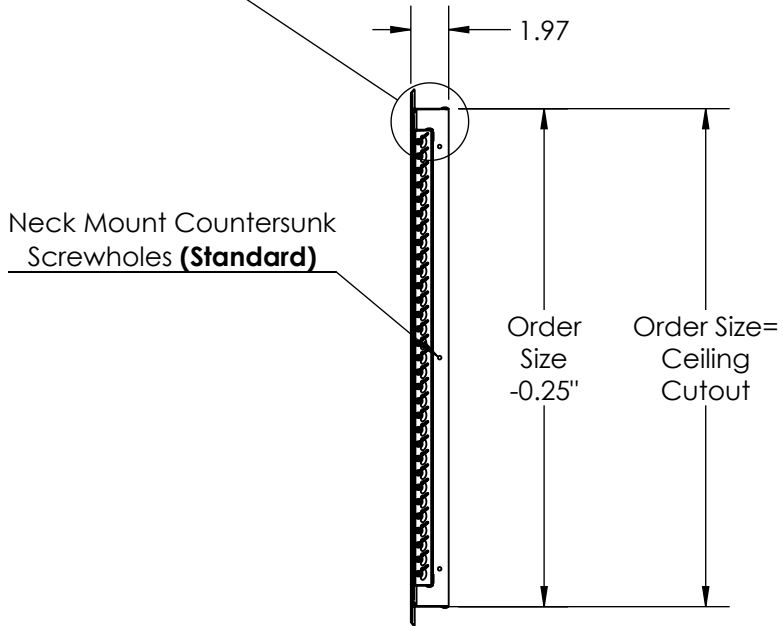
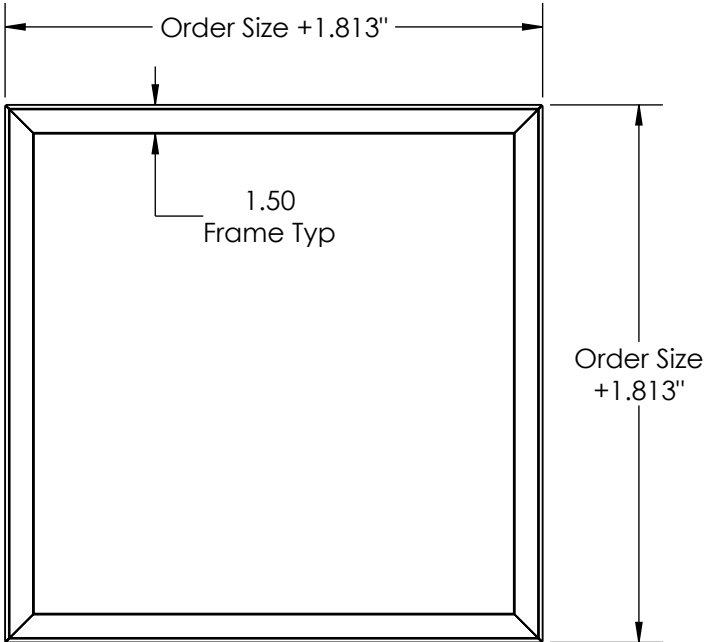
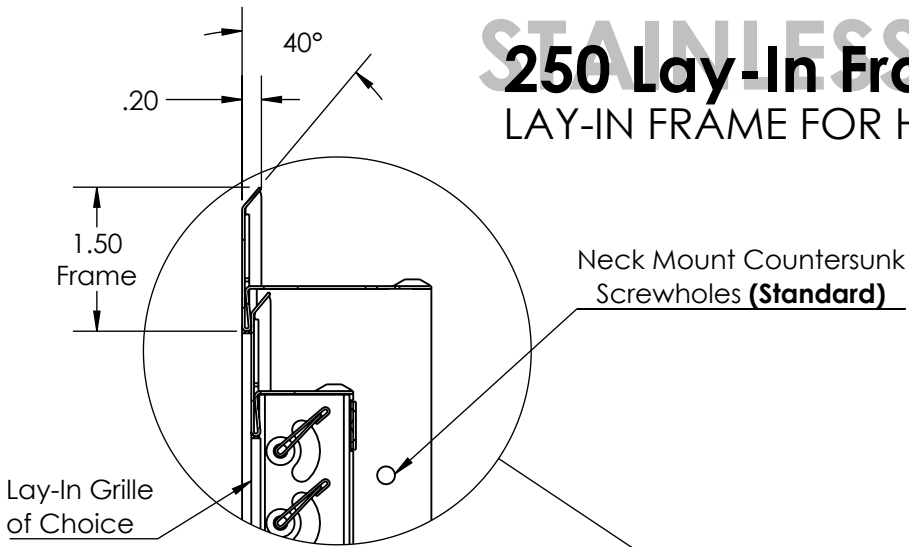

SECTION A-A



8701 Elmwood Ave #400
 Kansas City, MO 63132
 Ph: 816-231-5522 Fax: 816-231-8437
 800-247-5746 Email: robhaake@ajmfg.us
 Please Visit Our Web Site At: www.ajmfg.com

DRAWN SLG	MATERIAL 304SS	JOB NAME	TAG	QTY	REV # A
CHKD	FINISH #4 SATIN	ENGINEER	DRAWING NAME 250 Lay-In		SHT 2/2
APRVD	SIZE	CONTRACTOR			SCL 1:10
					DO NOT SCALE