

SSLBG

LINEAR BAR GRILLE - LIGHT DUTY

STANDARD CONSTRUCTION

- 304 Stainless Steel
- Countersunk Screw Holes
- Back Supports w/6" Spacing

ORDER SIZE (Duct Opening Size)

W: _____ x H: _____

MATERIAL OPTIONS

- 316 Stainless Steel

FINISH OPTIONS

- Polished
- White Antimicrobial Powder Coat
- Other: _____

BLADE SPACING OPTIONS

- 0.375 (Std)
- 0.50
- 0.66
- 0.75

BLADE DEFLECTION OPTIONS

- 0° (Std)
- 5°
- 15°
- 20°

DAMPER OPTIONS

- S-44 - Opposed Blade Damper

FEATURE OPTIONS

- No Countersunk Screw Holes

NOMINAL SIZE	OVERALL WIDTH (W)	OVERALL HEIGHT (H)	NECK WIDTH (NW)	NECK HEIGHT (NH)
24 x 24	25.81	25.81	23.75	23.75
65 x 36	66.81	37.81	64.75	35.75
Other	Nominal + 1.81	Nominal + 1.81	Nominal - 0.25	Nominal - 0.25

*** Note:**

72" Nominal Max Width for Single Section
72" Nominal Max Height for Single Section
(Multi-Sections Available)



AJ MANUFACTURING CO. INC.
8701 ELMWOOD AVE #400, KANSAS CITY, MO 64132
PH: 816.231.5522 / WWW.AJMFG.COM

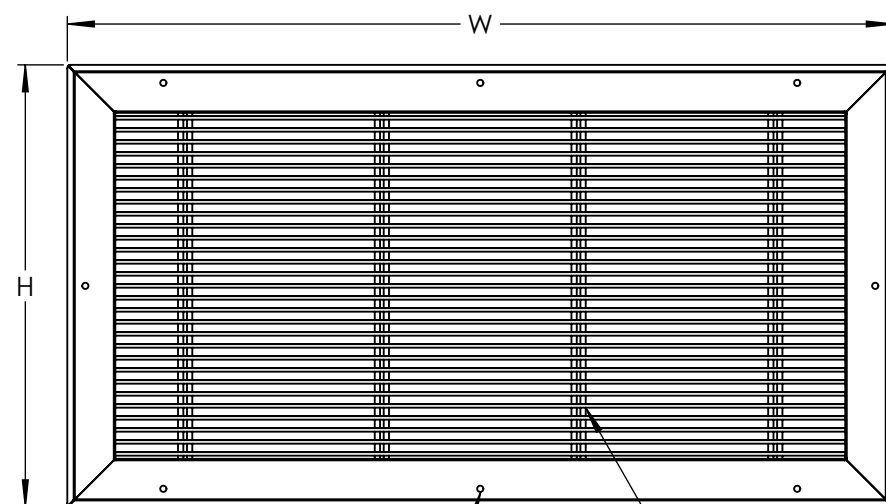
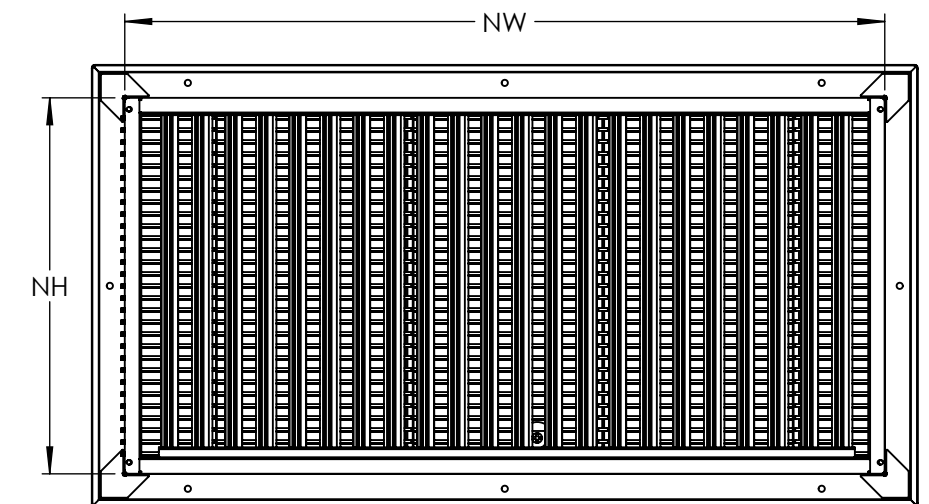
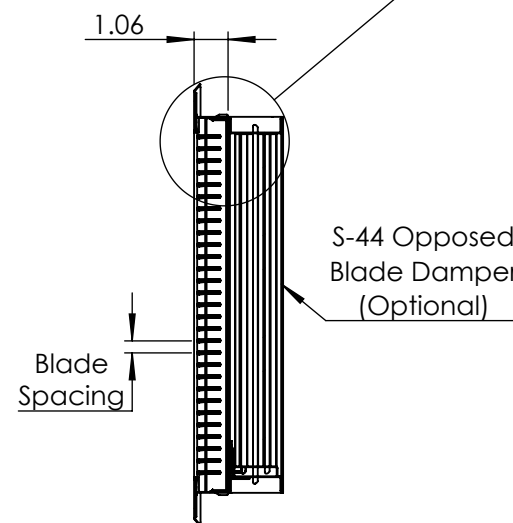
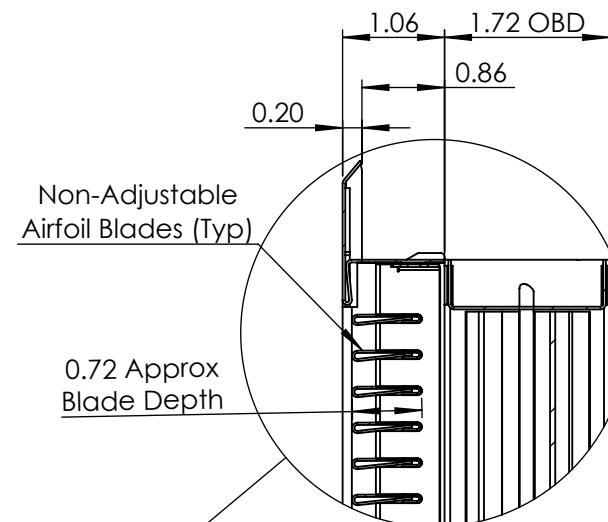
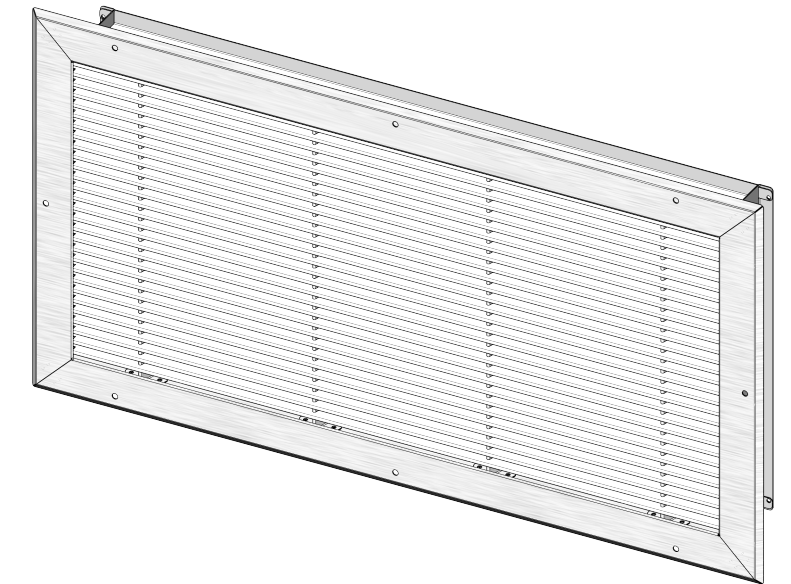

Opposed Blade Damper
Removed for Clarity

Back Supports (Typ)

Countersunk Screw Holes (Typ)

SECTION A-A